

HISTORIA DEL ARTE

ELEMENTOS FORMALES

ARQUITECTURA

Materiales	Barro, madera, piedra
Tratamiento	Adobe, ladrillo, sillares

Elementos sustentantes					
	<i>Soporte continuo</i>	Muro Y vanos	Regular: isódomo, almohadillado, a soga y tizón Irregular: sillarejo		
	<i>No continuo</i>	Pilar, pilastra Columna	Basa, fuste, capitel		
Elementos sustentados					
CUBIERTA	<i>Adintelada</i>				
	<i>Abovedada</i>	Arcos	<table border="1" style="width: 100%; border-collapse: collapse;"> <tr> <td style="width: 30%;">Partes Dovela, clave, imposta</td> <td>Tipos Medio punto, apuntado, carpanel, conopial, mixtilíneo, carpanel, conopial, lobulado</td> </tr> </table>	Partes Dovela, clave, imposta	Tipos Medio punto, apuntado, carpanel, conopial, mixtilíneo, carpanel, conopial, lobulado
	Partes Dovela, clave, imposta	Tipos Medio punto, apuntado, carpanel, conopial, mixtilíneo, carpanel, conopial, lobulado			
		Tipos	De cañón, de aristas, de crucería, media naranja, de lunetos		
		Cúpula	<table border="1" style="width: 100%; border-collapse: collapse;"> <tr> <td style="width: 30%;">Partes Linterna, bóveda, tambor</td> <td>Sobre Pechina, Trompas</td> </tr> </table>	Partes Linterna, bóveda, tambor	Sobre Pechina, Trompas
Partes Linterna, bóveda, tambor	Sobre Pechina, Trompas				
Plano	<i>Planta</i>	Basilical, Cruz latina, griega, poligonal, circular, oval			
	<i>Sección</i>	Longitudinal o transversal			
	<i>Alzado</i>				

PINTURA

Valores Técnicos	Materiales	Óleo, acuarela, fresco, encáustica, temple, pastel, acrílicos, collage,...	
	Soportes	Muro, tabla, lienzo, papel, pergamino	
Valores formales	Temas	Religioso, retrato, bodegón, paisaje, género, desnudo, informal, mitológico	
	Elementos Plásticos		
	Línea y modelado	Gradaciones de grises, variaciones de intensidad, escorzo	
	Perspectiva	Punto de fuga único, arquitectónica, aérea, variada	
	Color	Primarios: Amarillo, rojo, azul	
		Secundarios: Anaranjado, violeta, verde	
		Complementarios o no complementarios	
	Luz	Sin luz, envolviendo las formas, asociada al color, tenebrista, de un foco luminoso	

ESCULTURA

Valores técnicos	<i>Materiales</i>	Barro, piedra, metal, madera (policromada o no), marfil	
	<i>Técnicas</i>	Preparación: Se refiere a la que requiere el material	Ejecución: Modelado, tallado, esculpido,...
	<i>Tipos</i>	Bulto redondo: Busto, torso, estatua (sedente, yacente, ecuestre,...)	Relieve: Altorrelieve, bajo relieve, medio, ...
Valores formales	<i>Temas</i>	Básicamente los mismos de la pintura	
	<i>Composición</i>	Abierta o cerrada	
	<i>Calidad y textura</i>	Rugoso, pulido, fino, desbastado, inacabado, ...	
	<i>Espacio, volumen, movimiento</i>	Plano o tridimensional, estático o dinámico, abierto o cerrado	
Función	<i>Decorativa</i>		
	<i>estructural</i>	Función de estructura arquitectónica (estatua como columna, P.ej.)	
	<i>exenta</i>	En función del urbanismo (plaza, fuente,...)	

MUROS, COLUMNAS, PILASTRAS

ARTE

E
L
E
M
E
N
T
O
S
F
O
R
M
A
L
E
S

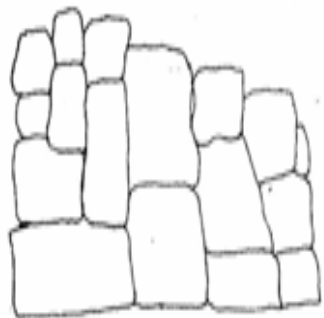

Ciclópeo

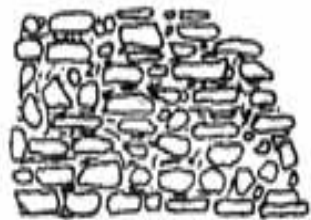

Mampostería

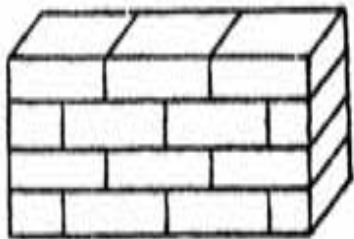

Isódome

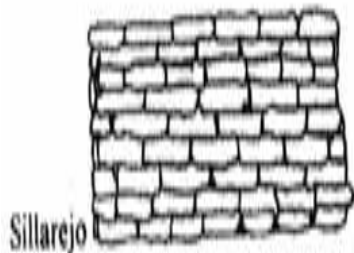

Sillarejo

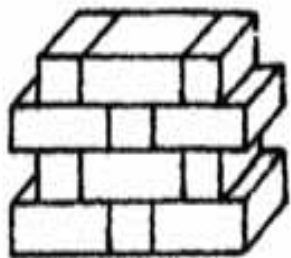

A soga y tizón

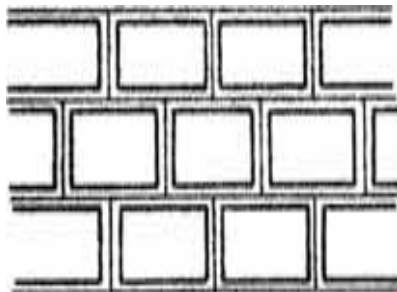

Almohadillado

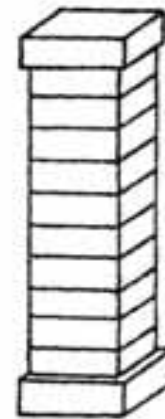
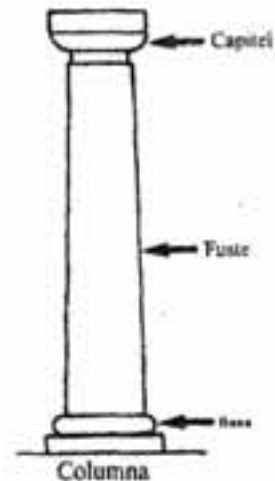
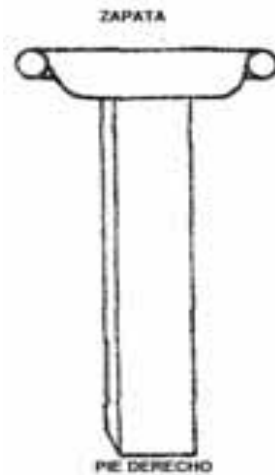

Pilar

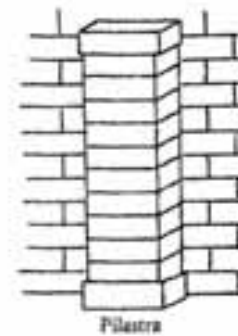

Pilastro

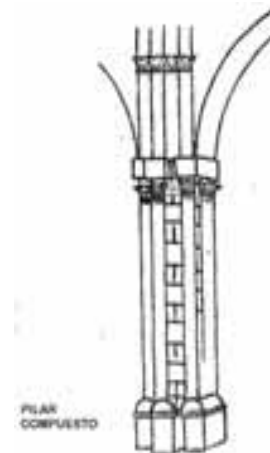

PILAR COMPUESTO

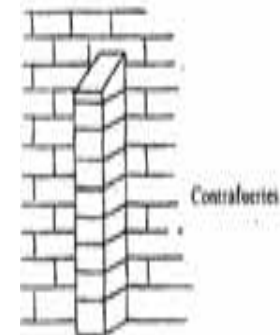

Contrafuertes

ELEMENTOS SUSTENTANTES Y SUSTENTADOS

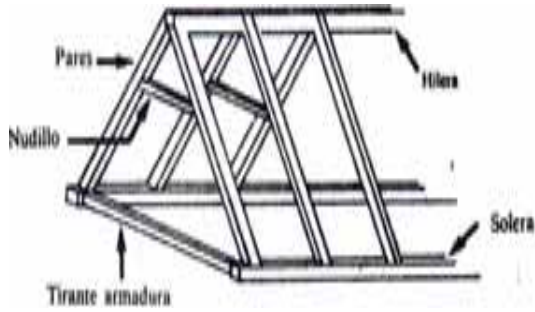
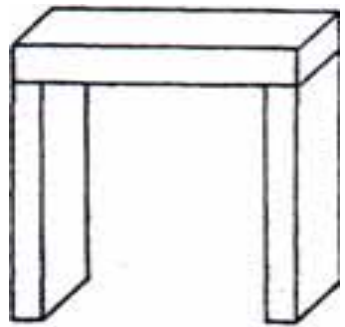

ARTE

E
L
E
M
E
N
T
O
S
F
O
R
M
A
L
E
S

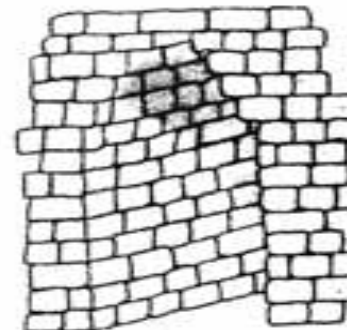

Falsa bóveda

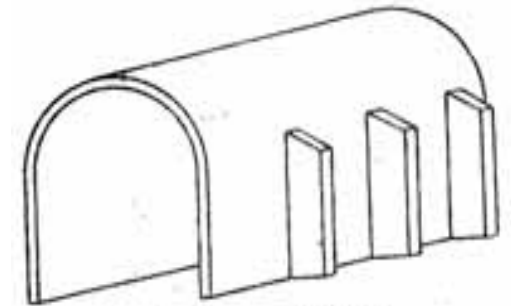

Bóveda de cañón con contrafuertes

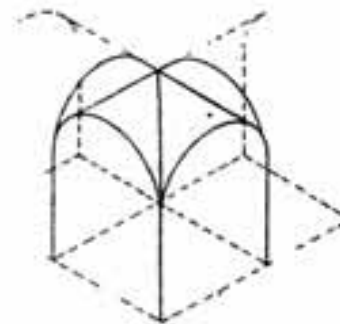
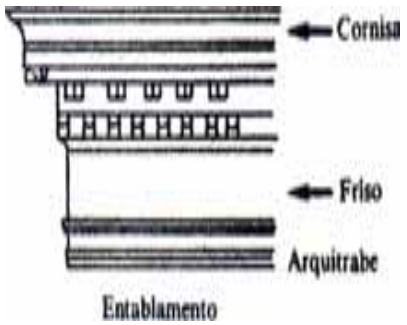

De aristas

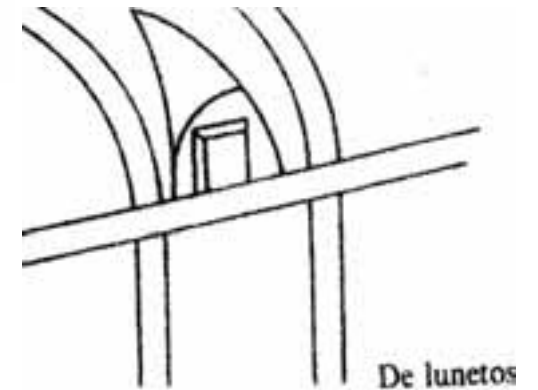
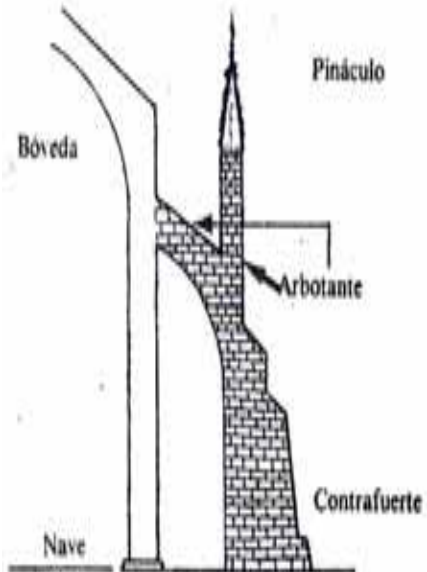

De lunetos

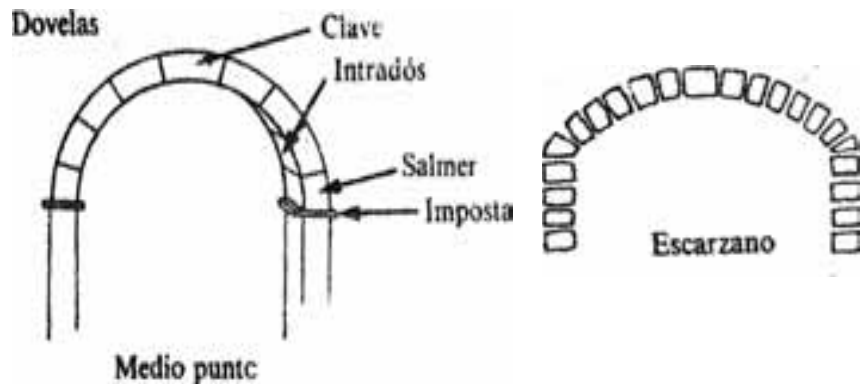

ARCOS

ARTE

**E
L
E
M
E
N
T
O
S
F
O
R
M
A
L
E
S**

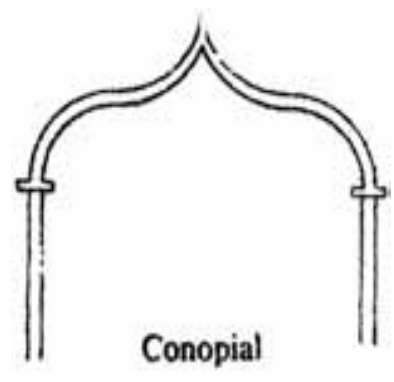
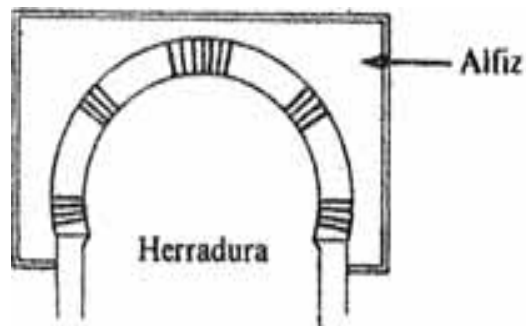
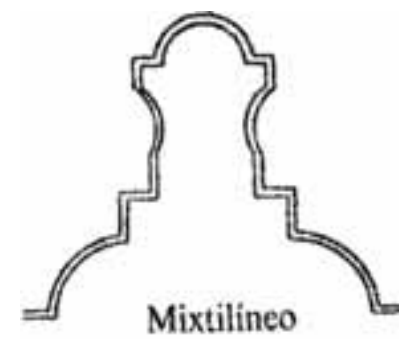
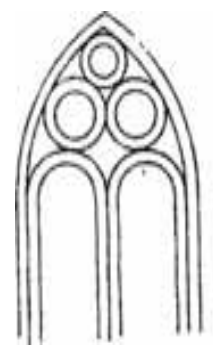
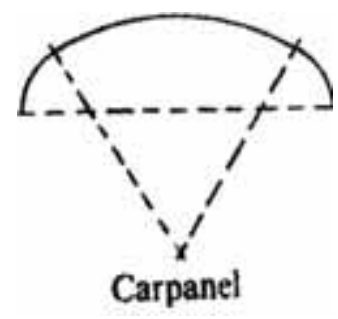
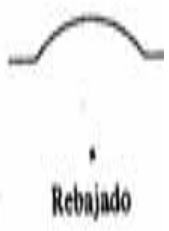
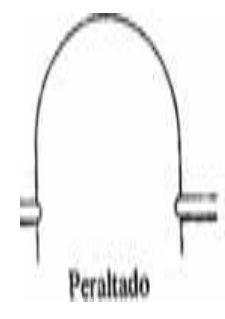

ARTE

ELEMENTOS FORMALES

FORMA

- CIRCULAR
- CRUZ
- POLIGONAL
- RECTANGULAR

COLUMNAS Y PILARES

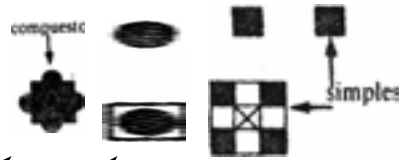

Bóveda de cañón
(sin expresión en planta)

MURO

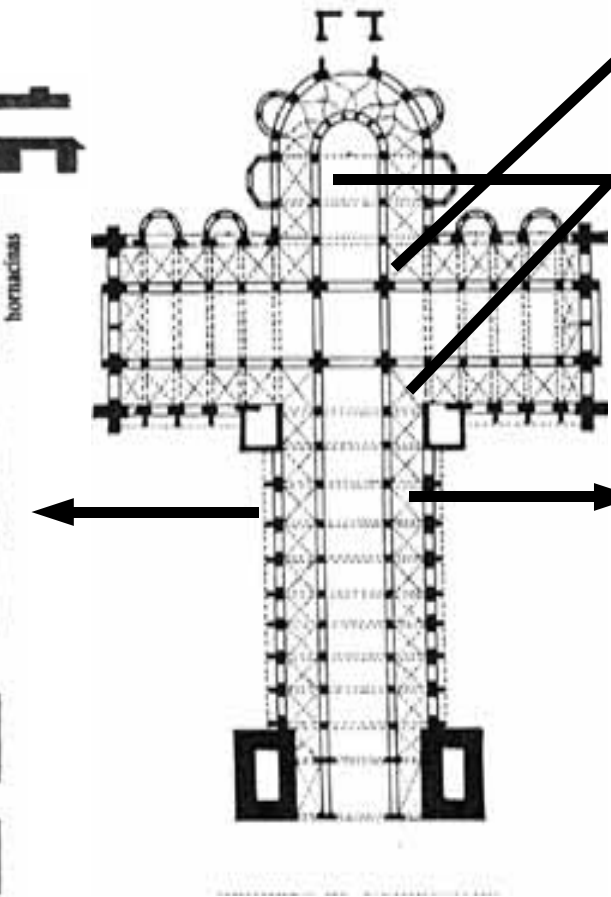

De lunetos.



Arista



Trompas o pechinas

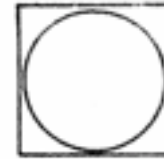

Trompa o pechina

Terceletes.
Sexpartita.
Eirrellada.

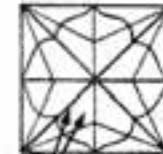
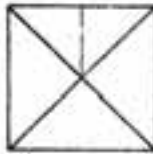

Tercelete

BÓVEDAS Y CÚPULAS

COMENTARIO PLANTAS

ARTE

ELEMENTOS FORMALES

PLANTAS LONGITUDINALES

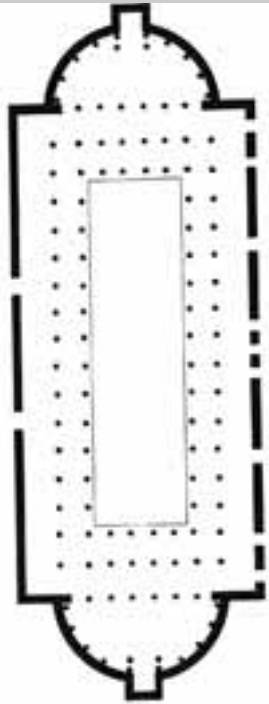

Basilica.
Basílica Ulpia

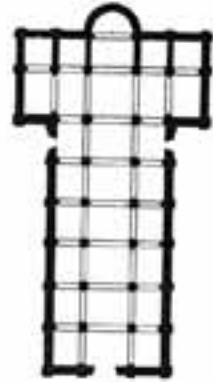

Fig. 182
Cruz latina.
Iglesia del monasterio de La Oliva.

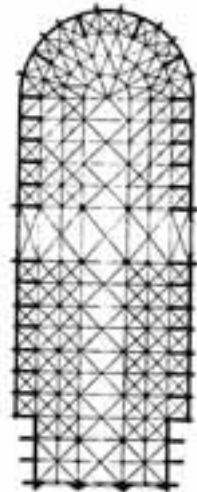
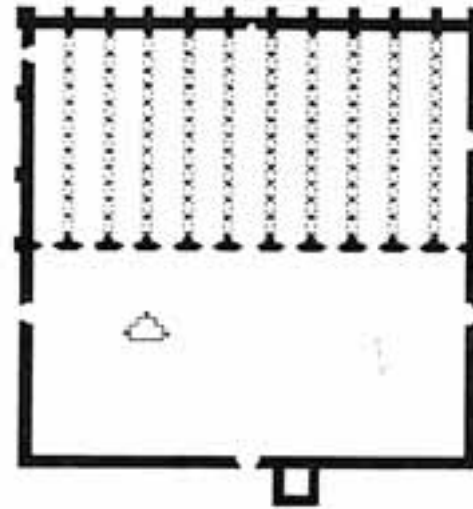

Fig. 183
Salón.
Catedral de Notre Dame de Paris.

ISLÁMICA



Reconstrucción ideal de la mezquita de Abderramán I (Cò)

CENTRALES

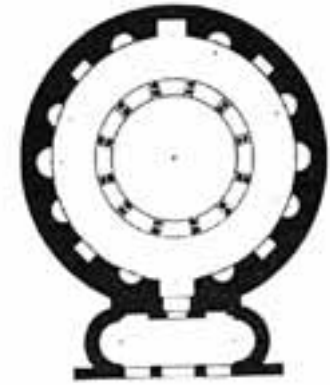

Circular.
Mausoleo de Santa Geronziana.

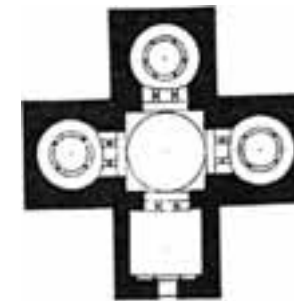

Cruz griega.
San Fructuano de Montelión.

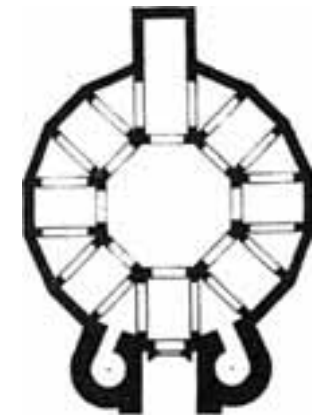

Poligonal.
Capilla Palatina de Aquisgran

TIPOS DE PLANTAS

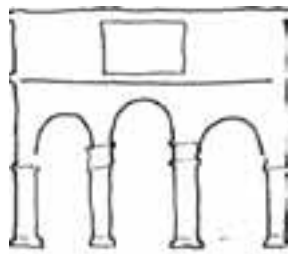

De triunfo.

ARCOS



Torales.

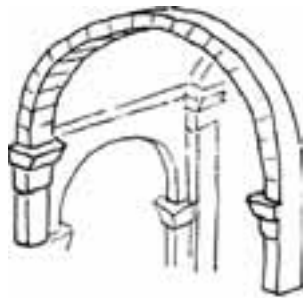

Fajón.

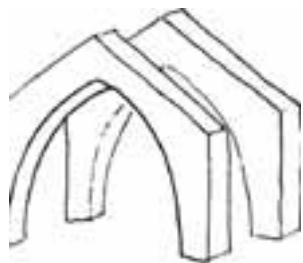

Diafragma.



Cruceros.

BÓVEDAS

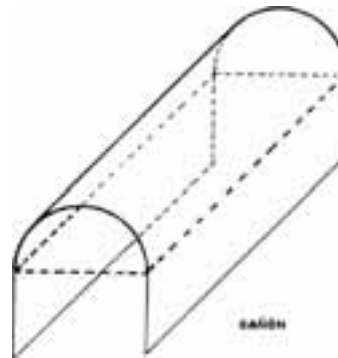

CAÑÓN

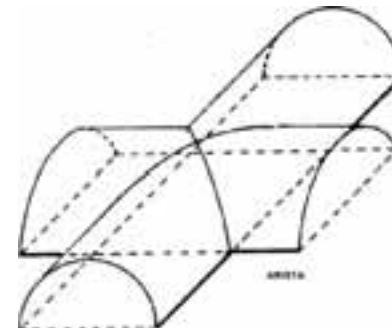

ARTEO

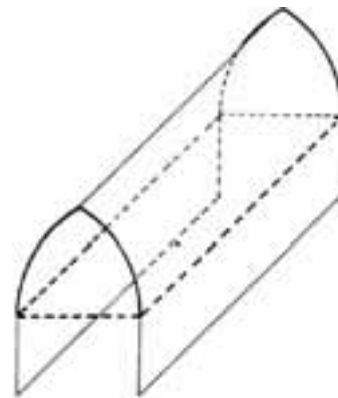

De cañón apuntado.

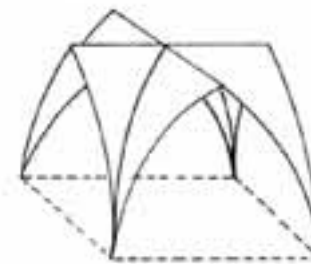

CRUCERÍA

ARTE

ELEMENTOS FORMALES

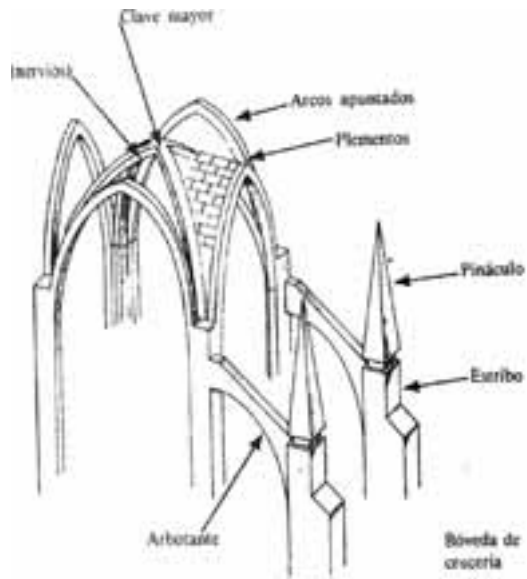

ARISTA O CAÑÓN

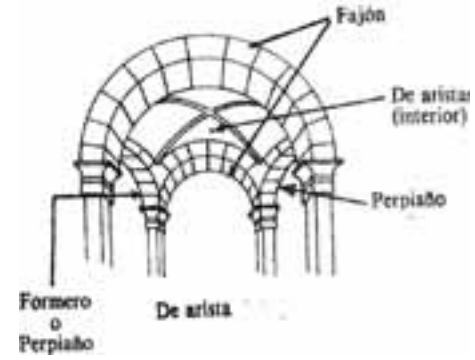

BÓVEDA CRUCERÍA

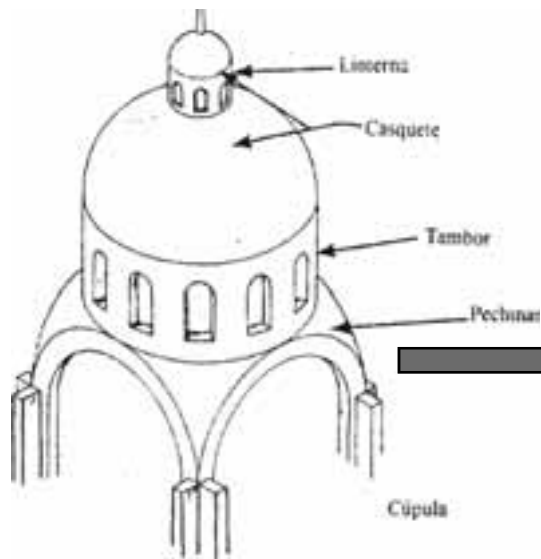

CÚPULA

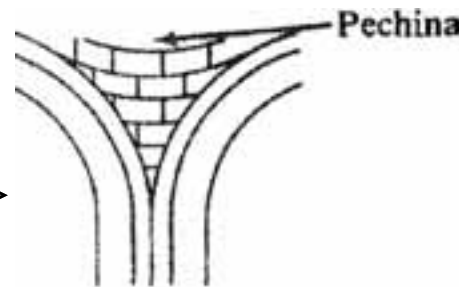
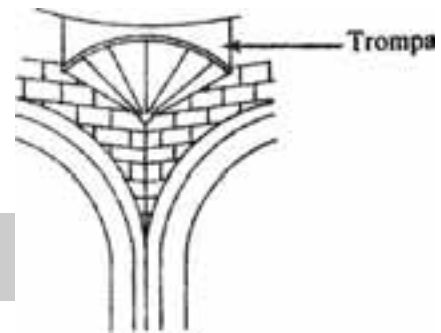

SOBRE TROMPA O PECHINA

ESTRUCTURA

BÓVEDAS Y CÚPULAS